

Card Guides

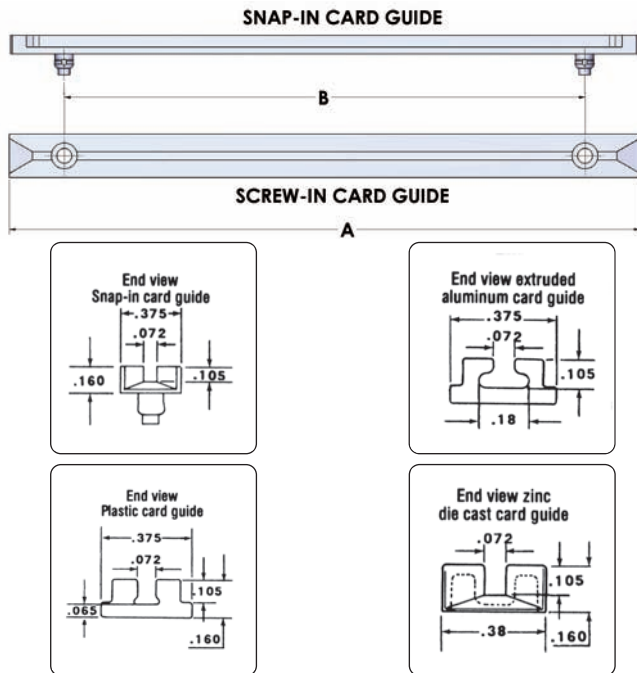

High quality card guides feature tapered slots for easy insertion. Snap-in nylon models provide easy installation and removal without tools, and can be positioned at 0.25" increments (64 0.156" holes on 0.250" centers) when used with Vector-Pak T-struts (TS169-6/90). Screw-mounted models (installation hardware included) are available in metal or plastic and provide variable positioning along entire length of strut. Holes for mounting guides to struts are based on center-to-center multiples of 0.75". All materials are flame retardant.

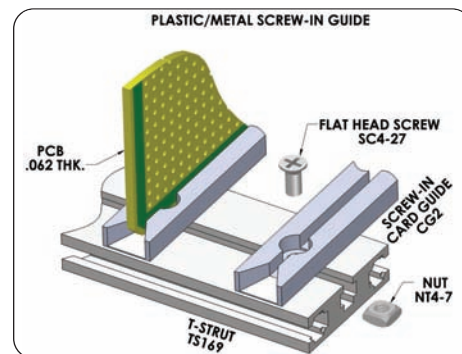

Metal or plastic screw down card guides attach with SC4-27/25 flat head screw and NT4-7PA square nut

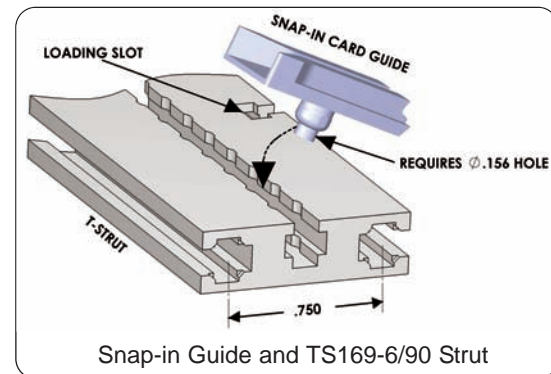

Part No.	Type	Length A	Centers B	Card Length	Application
CG2-45P	Plastic, Screw	2.89"	2.25"	4.50"	Subrack series 12, 13, 14, 17, 18 & 100 and Vector P series sidewalls
CG2-45S	Nylon, Snap-in	3.17"	2.25"	4.50"	
CG2-50P	Plastic, Screw	4.39"	3.75"	5.00"	
CG2-65M	Metal, Die Cast Screw	5.42"	4.50"	6.50"	
CG2-65P	Plastic, Screw	5.42"	4.50"	6.50"	
CG2-65S	Nylon, Snap-in	5.42"	4.50"	6.50"	Subrack series 14, 15, 17, 18 and 100 and Vector P series sidewalls ending in 119 or 156
CG2-80P	Plastic, Screw	6.64"	6.00"	8.00"	
CG2-80S	Nylon, Snap-in	6.93"	6.00"	8.00"	
CG2-95M	Metal, Screw	8.14"	7.50"	9.50"	
CG2-95P	Plastic, Screw	8.14"	7.50"	9.50"	
CG2-95S	Nylon, Snap-in	8.43"	7.50"	9.50"	CCA19
CG2-135M	Metal, Screw	13.19"	12.55"	13.50"	
CG2-135P	Plastic, Screw	13.19"	12.55"	13.50"	

Packages of 12 ea. Screw down types include installation hardware and are available in custom lengths on request.

Free Standing Connector Mounted Card Guides

Secure connection, rugged support of 0.062" thick PCB's when space is limited. P/N BR27D is die cast of zinc alloy#3 (ASTM B240-06). Other sizes are 6063 T5 aluminum alloy. All sizes include HD55 hardware kit to attach connector to board. Connector not included (See Page 70). All sold as a pair and are fully RoHS compliant.

Part No.	Use With Connector	For Use With	Material
BR27D	R644, R644-2, R644-3C, R644-3F	4.5"W (3677, 3682 & 3662 series), Page 57	Zinc #3
BR27-1	R636-1, R636-2	4.5"W (3719 series), Page 58	Al Alloy 6063 T5
BR27-3	R630	2.73"W (3797 series), Page 56	Al Alloy 6063 T5
BR27-5	R656-1, R656-2	4.5"W (4610 series), Page 63	Al Alloy 6063 T5

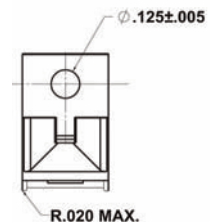
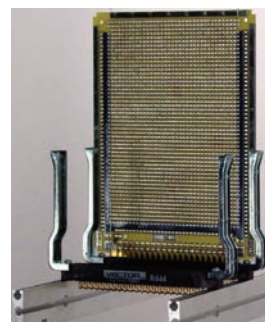

BR27D Zinc die-cast model shown

Details of BR27-1, -3 & -5 at www.vectorelect.com

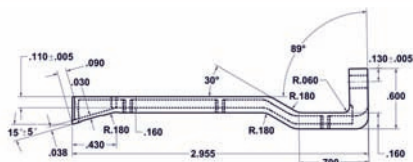

Specification subject to change without notice

800-423-5659

www.vectorelect.com



8 7 6 5 4 3 2 1

REVISIONS				
ZONE	REV.	DESCRIPTION	DATE	APPROVED
ALL	F		01/08/09	

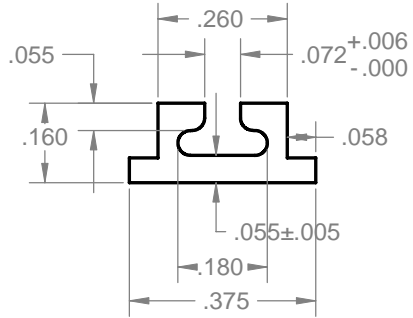

SECTION K-K
SCALE 4:1

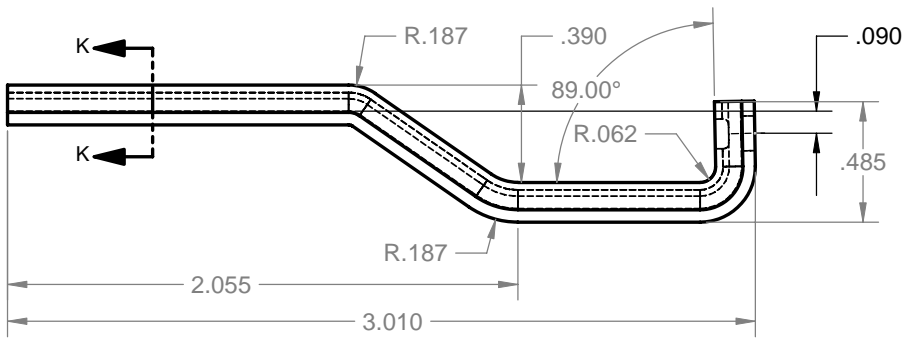
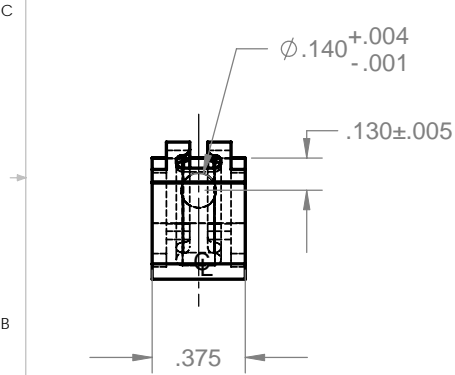
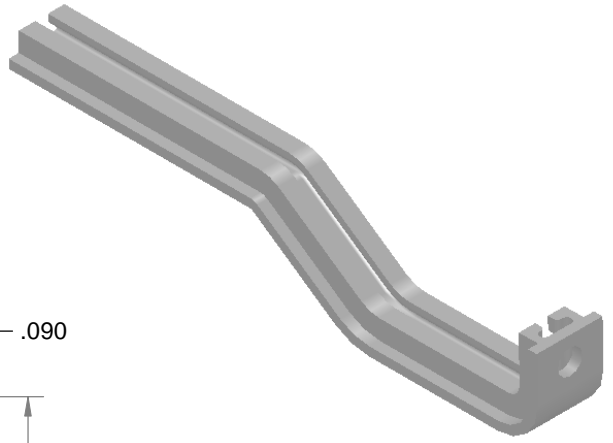
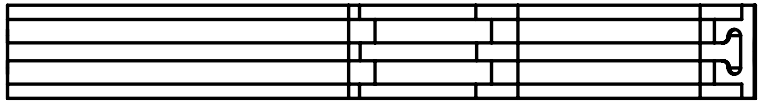

- 4. PARTS TO BE DEGREASED AFTER FABRICATION
- 3. PARTS TO BE FREE OF EXCESSIVE BURRS AND SURFACE SCRATCHES
- 2. FINISH: CLEAR ANODIZE
- 1. MATERIAL: ALUM. EXTRUSION 6063-T5

NOTES: UNLESS OTHERWISE SPECIFIED.

PROPRIETARY AND CONFIDENTIAL
THE INFORMATION CONTAINED IN THIS DRAWING IS THE SOLE PROPERTY OF VECTOR ELECTRONICS & TECH., INC. ANY REPRODUCTION IN PART OR AS A WHOLE WITHOUT THE WRITTEN PERMISSION OF VECTOR ELECTRONICS & TECH., INC. IS PROHIBITED.

UNLESS OTHERWISE SPECIFIED:		NAME	DATE	VECTOR ELECTRONICS & TECHNOLOGY, INC. CA 91605	11115 VANOWEN ST., NORTH HOLLYWOOD, CA 91605	
DIMENSIONS ARE IN INCHES TOLERANCES: FRACTIONAL ± ANGULAR: ±5° TWO PLACE DECIMAL ±.03 THREE PLACE DECIMAL ±.010 INTERPRET GEOMETRIC TOLERANCING PER:		DRAWN	TRUSHAR		01/08/09	CARD GUIDE BR27-3
MATERIAL 1		CHECKED				
FINISH 2		ENG APPR.				
DO NOT SCALE DRAWING		MFG APPR.				
		Q.A.			SIZE DWG. NO.	
		THIRD ANGLE PROJECTION			REV	
					B M5474-1-8 F	
					SCALE: 1:1 WEIGHT: SHEET 1 OF 1	

8 7 6 5 4 3 2 1

8 7 6 5 4 3 2 1

REVISIONS				
ZONE	REV.	DESCRIPTION	DATE	APPROVED
ALL	F		01/08/09	

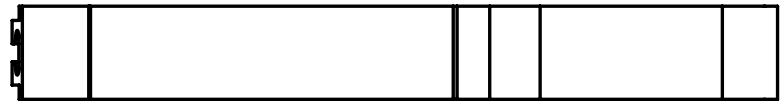
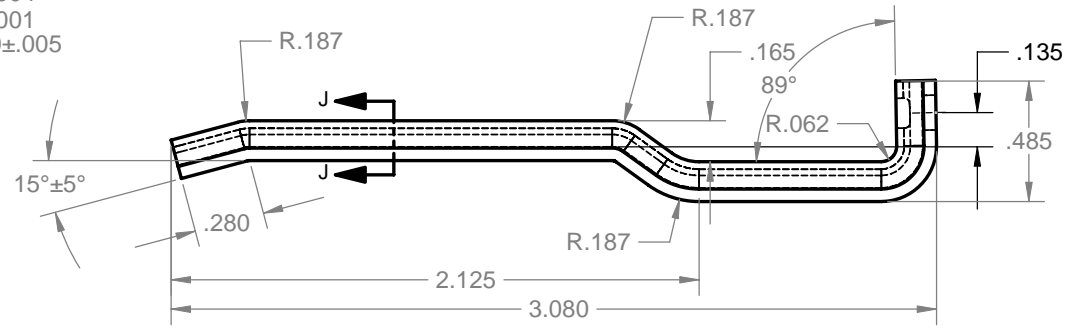
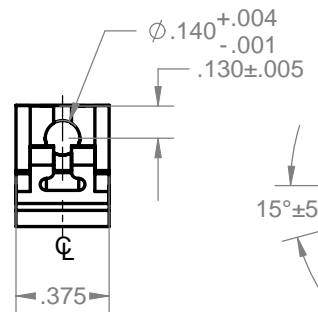
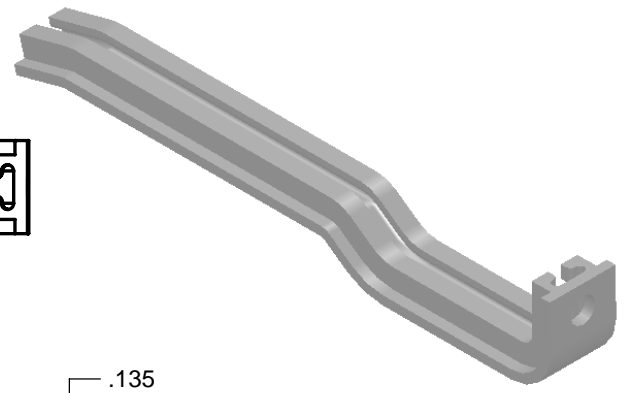
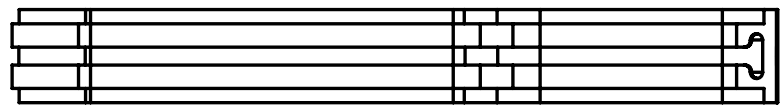
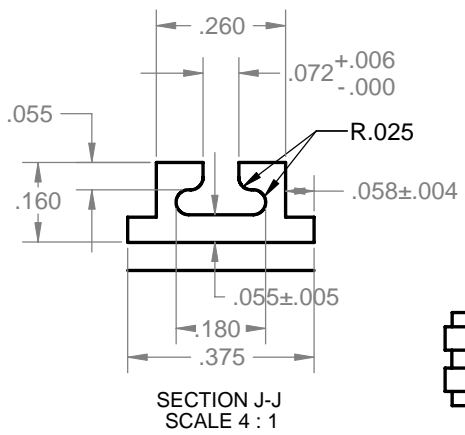

- 4. PARTS TO BE DEGREASED AFTER FABRICATION
- 3. PARTS TO BE FREE OF EXCESSIVE BURRS AND SURFACE SCRATCHES
- 2. FINISH: CLEAR ANODIZE
- 1. MATERIAL: ALUM. EXTRUSION 6063-T5

NOTES: UNLESS OTHERWISE SPECIFIED.

PROPRIETARY AND CONFIDENTIAL
THE INFORMATION CONTAINED IN THIS DRAWING IS THE SOLE PROPERTY OF VECTOR ELECTRONICS & TECH., INC. ANY REPRODUCTION IN PART OR AS A WHOLE WITHOUT THE WRITTEN PERMISSION OF VECTOR ELECTRONICS & TECH., INC. IS PROHIBITED.

UNLESS OTHERWISE SPECIFIED:
DIMENSIONS ARE IN INCHES
TOLERANCES:
FRACTIONAL ±
ANGULAR: ±5°
TWO PLACE DECIMAL ±.03
THREE PLACE DECIMAL ±.010
INTERPRET GEOMETRIC TOLERANCING PER:
MATERIAL **1**
FINISH **2**
DO NOT SCALE DRAWING

NAME	DATE
DRAWN TRUSHAR	01/08/09
CHECKED	
ENG APPR.	
MFG APPR.	
Q.A.	

VECTOR ELECTRONICS & TECHNOLOGY, INC. 11115 VANOWEN ST., NORTH HOLLYWOOD, CA 91605

CARD GUIDE BR27-1

SIZE DWG. NO. **B M5474-1-5** REV **F**

SCALE: 1:1 WEIGHT: SHEET 1 OF 1



8 7 6 5 4 3 2 1

8 7 6 5 4 3 2 1

REVISIONS				
ZONE	REV.	DESCRIPTION	DATE	APPROVED
ALL	F		01/08/09	

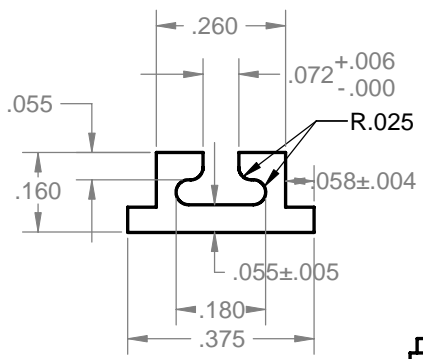

SECTION K-K
SCALE 4 : 1

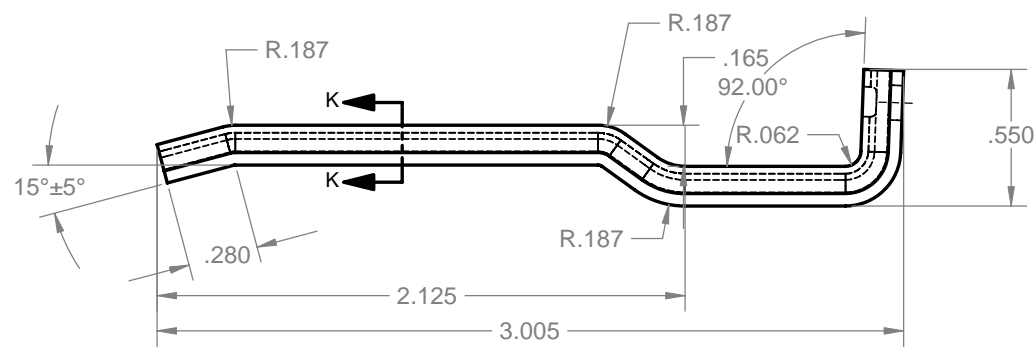
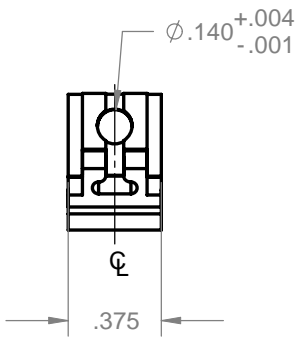
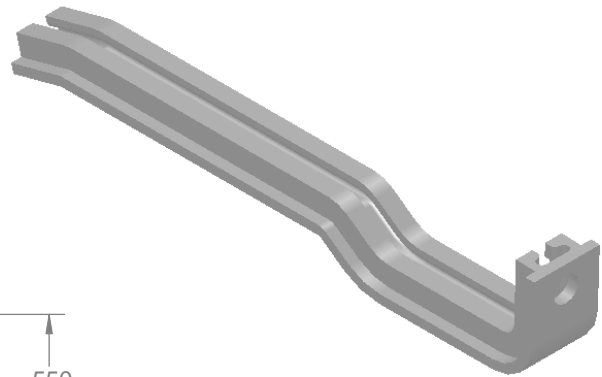

- 4. PARTS TO BE DEGREASED AFTER FABRICATION
- 3. PARTS TO BE FREE OF EXCESSIVE BURRS AND SURFACE SCRATCHES
- 2. FINISH: CLEAR ANODIZE
- 1. MATERIAL: ALUM. EXTRUSION 6063-T5

NOTES: UNLESS OTHERWISE SPECIFIED.

PROPRIETARY AND CONFIDENTIAL
THE INFORMATION CONTAINED IN THIS DRAWING IS THE SOLE PROPERTY OF VECTOR ELECTRONICS & TECH., INC. ANY REPRODUCTION IN PART OR AS A WHOLE WITHOUT THE WRITTEN PERMISSION OF VECTOR ELECTRONICS & TECH., INC. IS PROHIBITED.

UNLESS OTHERWISE SPECIFIED:
DIMENSIONS ARE IN INCHES
TOLERANCES:
FRACTIONAL ±
ANGULAR: ±5°
TWO PLACE DECIMAL ±.03
THREE PLACE DECIMAL ±.010
INTERPRET GEOMETRIC TOLERANCING PER:
MATERIAL **1**
FINISH **2**
DO NOT SCALE DRAWING

NAME	DATE
DRAWN TRUSHAR	01/08/09
CHECKED	
ENG APPR.	
MFG APPR.	
Q.A.	

VECTOR ELECTRONICS & TECHNOLOGY, INC. 11115 VANOWEN ST., NORTH HOLLYWOOD, CA 91605

CARD GUIDE BR27-5

SIZE DWG. NO. **B M5474-1-12** REV **F**

SCALE: 1:1 WEIGHT: SHEET 1 OF 1



8 7 6 5 4 3 2 1